

## 2-D Exploded Diagram

(Pins, bolt, and skewer not shown)

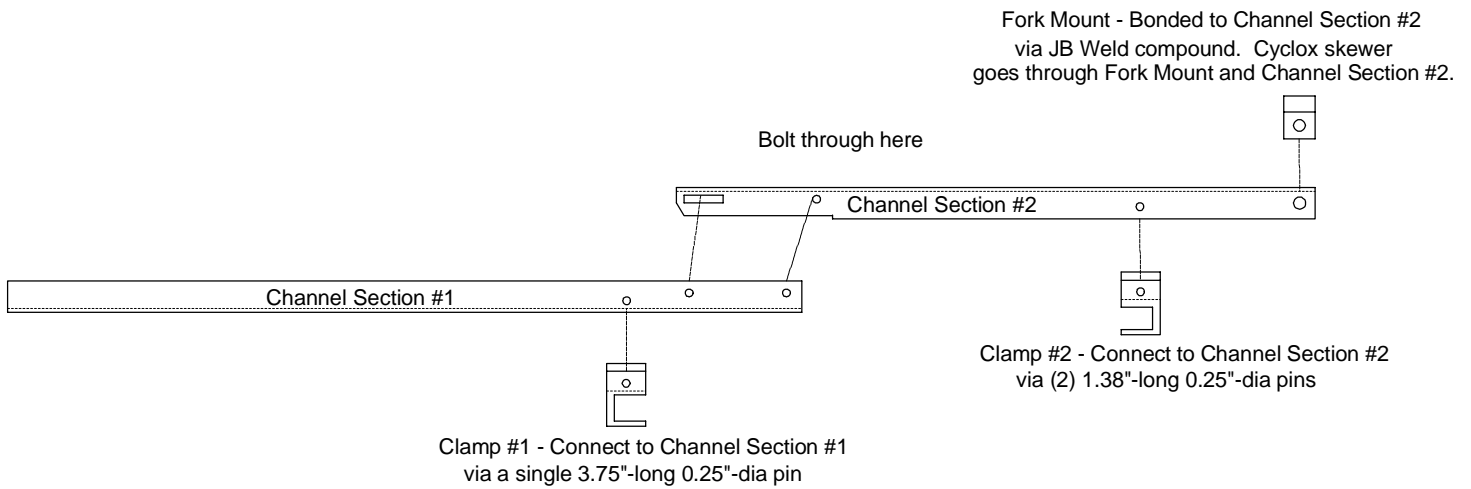

NOTES:

- 1. MATERIAL: AI
- 2. FINISH: AS MACHINED
- 3. DIMENSIONS IN INCHES
- 4. TOLERANCES: x.xx +/- 0.015

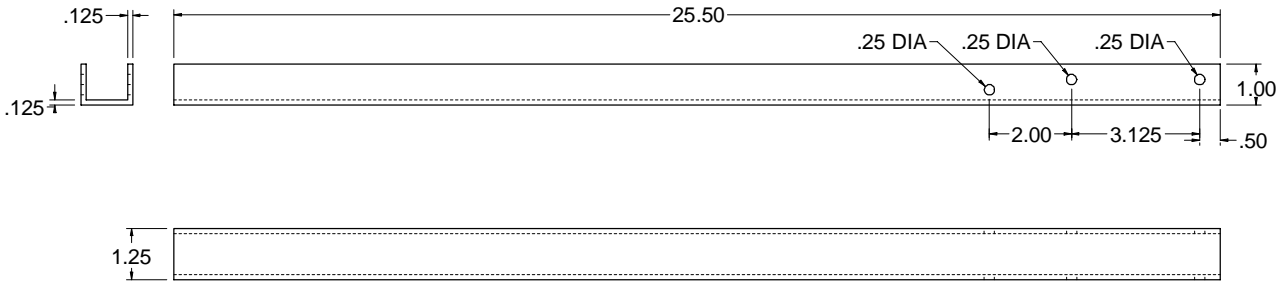

## Channel Section #1

Felix Wong

Rev: A

Feb. 12, 1996

NOTES:

- 1. MATERIAL: Al
- 2. FINISH: AS MACHINED
- 3. DIMENSIONS IN INCHES
- 4. TOLERANCES: x.xx +/- 0.015

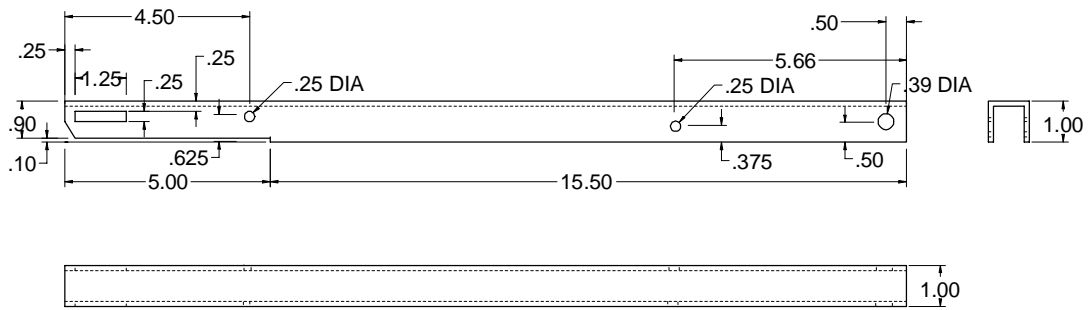

## Channel Section #2

Felix Wong

Rev: A

Feb. 12, 1996

NOTES:

1. MATERIAL: Al
2. FINISH: AS MACHINED
3. DIMENSIONS IN INCHES
4. TOLERANCES:  $x.xx \pm 0.015$

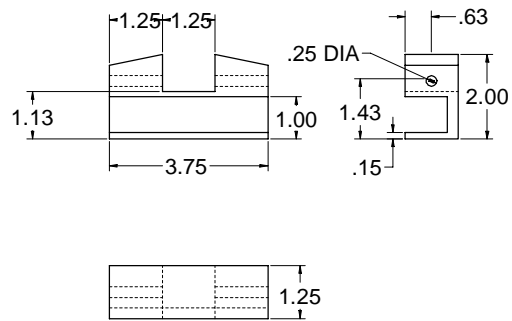

# Clamp #1

Felix Wong

Rev: A

Feb. 12, 1996

NOTES:

- 1. MATERIAL: Al
- 2. FINISH: AS MACHINED
- 3. DIMENSIONS IN INCHES
- 4. TOLERANCES: x.xx +/- 0.015

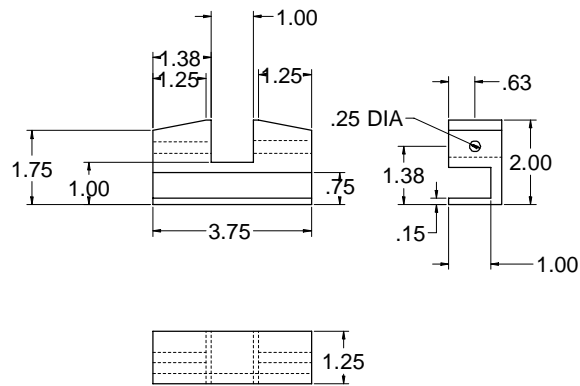

## Clamp #2

Felix Wong

Rev: A

Feb. 12, 1996

NOTES:

1. MATERIAL: Al
2. FINISH: AS MACHINED
3. DIMENSIONS IN INCHES
4. TOLERANCES: x.xx +/- 0.015

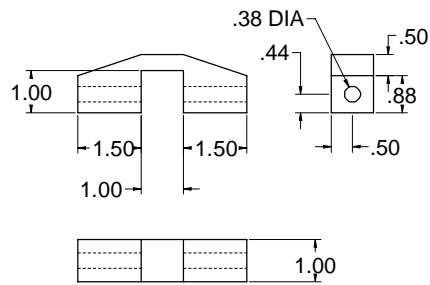

# Fork Mount

Felix Wong

Rev: A

Feb. 12, 1996